

*Stereophonic*

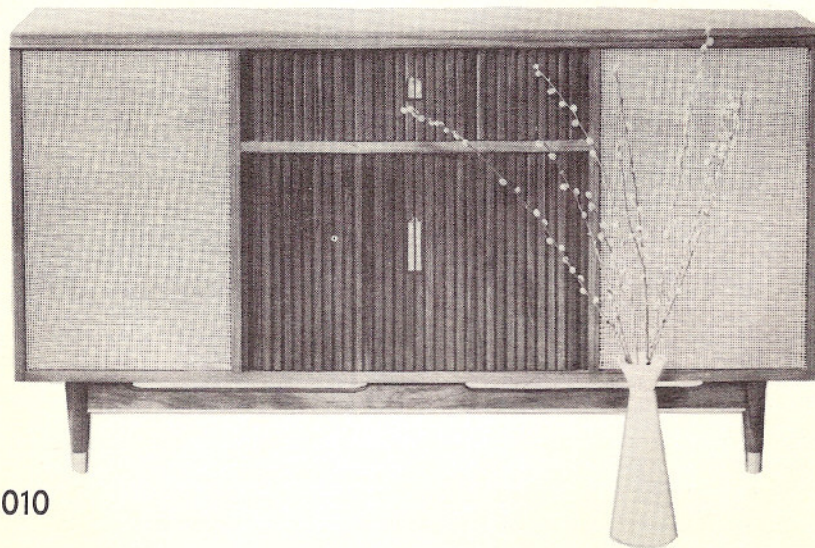

**THE FISHER  
STATESMAN  
SERVICE  
MANUAL**



MODEL 1010

CHASSIS SERIAL NUMBERS  
FROM 10001 TO 19999 INCLUSIVE

PRICE: \$1.00

FISHER RADIO CORPORATION • NEW YORK

CHASSIS SERIAL NUMBERS  
FROM 10001 TO 19999 INCLUSIVE

**THE FISHER IOIO**



# PARTS DESCRIPTION LIST • TUNER AND PREAMPLIFIER

## CAPACITORS

10% tolerance for all fixed capacitors, unless otherwise noted or marked GMV (guaranteed minimum value.)

Symbol	Description	Part No.
C1	Ceramic, 24uuf 5% N150, 1000V	C50070-8
C2	Ceramic, 8 uuf ± .5uuf NPO; 500V	CC20CJ080D5
C3	Ceramic, 5uuf ± .5uuf NPO; 500V	CC20CJ050D5
C4	Ceramic, 100uuf N1500; 1000V	C50070-6
C5	Ceramic trimmer	C662-123
C6	AM variable	C684-127
C7	FM variable	C726-116
C8	Ceramic, 100 uuf GMV, N1500; 1000V	C50070-5
C9	Ceramic, 100 uuf N1500; 1000V	C50070-6
C10, 11, 12	Ceramic, Feedthru, .001 uf GMV	C592-187
C13	Ceramic, .02uf + 80 — 20%; 500V	C50089-4
C14	Ceramic, Feedthru, .001 uf; GMV	C592-187
C15	Ceramic, .02uf + 80 — 20%; 500V	C50089-4
C16	Ceramic, .001uf; 1000V	C50072-3
C17	Ceramic, .02uf + 80 — 20%; 500V	C50089-4
C18	Ceramic, .005uf 20%; 500V	C50089-1
C19	Ceramic, 8uuf ± .5uuf; NPO, 500V	CC20CJ080D5
C20	Ceramic, .68uuf, 500V	C50077-6N
C21	Ceramic, Trimmer	C662-123
C22	Ceramic, 10uuf ± .5uuf, NPO; 500V	CC20CJ100D5
C23	Ceramic, 100uuf, N1500; 1000V	C50070-6
C24	Ceramic, 100uuf, GMV, N1500, 1000V	C50070-5
C25	Ceramic, 68uuf, N750; 500V	CC20UJ680K5
C26	Ceramic, 100uuf, N1500; 1000V	C50070-6
C27	Molded, .01uf 20%; 600V	C2747
C28	Ceramic, 5uuf ± .5uuf N150, 500V	CC20PJ050D5
C29	Ceramic, 5uuf ± .5uuf N220, 500V	CC20RH050D5
C30	Ceramic, 47uuf N750; 1000V	C50070-4
C31	Ceramic, trimmer	C662-123
C32	Ceramic, feedthru .001uf GMV	C592-187
C33	Ceramic, 10uuf ± .5uuf NPO; 500V	CC20CJ100D5
C34	Ceramic, 24uuf 5%; N150; 1000V	C50070-8
C35	Ceramic, 100uuf GMV, N1500; 1000V	C50070-5
C36	Ceramic, 100uuf 5%, N1500; 1000V	C50070-19
C37	Ceramic, .001uf, 1000V	C50072-3
C38	Ceramic, feedthru .001 uf GMV	C592-187
C39, 40	Ceramic, .02uf + 80 — 20% 500V	C50089-4
C41	Ceramic, .005uf 20%; 500V	50089-1
C42	Electrolytic four section:	C50180-3
	A 40uf 350V	
	B 40uf 300V	
	C 40uf 300V	
	D 40uf 250V	
C43	Electrolytic to section:	C50180-7
	A 1000uf 30V	
	B 1000uf 30V	
C44	Ceramic feedthru .001uf GMV	C592-187
C45	Mica, 470uuf 5%, 300V	C3334
C46, 47	Ceramic, .005uf 20%; 500V	C50089-1
C48	Ceramic, .0027uf, 1000V	C50072-17
C49	Electrolytic, three section:	C50180-4
	A 40uf 250V	
	B 40uf 250V	
	C 40uf 250V	
C50, 51, 52	Ceramic, .005uf 20%; 500V	C50089-1
C53	Mica, 470uuf, 5%; 300V	C3334
C54	Mylar, .047 uf; 250V	C50197-52
C55	Electrolytic, two section:	C50180-5
	A 40uf 250V	
	B 40uf 250V	
C56	Ceramic, .005uf 20%; 500V	C50089-1
C57	Ceramic, .02uf + 80 — 20%; 500V	C50089-4
C58	Ceramic, .0027uf, 1000V	C50072-17
C59	Ceramic, .02uf + 80 — 20%; 500V	C50089-4
C60, 61	Ceramic, .005uf 20%; 500V	C50089-1
C62	Mica, 470 uuf 5%; 300V	C3334
C63, 64	Ceramic, .005uf, 20%, 500V	C50089-1
C65	Ceramic, 47uuf, N750; 1000V	C50070-4
C66	Ceramic, 220uuf 1000V	C50072-20
C67	Mica, 470uuf 5%; 300V	C3334
C68	Ceramic, 220 uuf, 1000V	C50072-20
C69	Ceramic, .0027uf; 1000V	C50072-17
C70	Ceramic, .005uf 20%; 500V	C50089-1
C71	Ceramic, .02uf + 80 — 20%; 500V	C50089-4
C72	Ceramic, 5uuf ± .5uuf, NPO; 500V	CC20CJ050D5
C73	Ceramic, 24uuf, 5%; 1000V	C50070-8
C74	Ceramic, .005uf 20%; 500V	C50089-1
C75	Electrolytic, 2uf; 70V	C721-142
C76	Mylar, .1uf 10%; 250V	C50197-54
C77, 78	Ceramic, .005uf 20%; 500V	C50089-1
C79	Ceramic, 1uuf, 20% P100; 100V	C50070-1

Symbol	Description	Part No.
C80	Ceramic, .005uf 20%; 500V	C50089-1
C81	Ceramic, 560uuf; 1000V	C50072-14
C82	Ceramic, 12uuf; NPO, 1000V	C50070-2
C83, 84	Ceramic, .005uf 20%, 500V	C50089-1
C85	Mica trimmer	C629-151-5
C86	Ceramic, .0027uf 1000V	C50072-17
C87	Ceramic, 12uuf, NPO, 1000V	C50070-2
C88	Mylar, .047uf, 250V	C50197-52
C89	Ceramic, .005uf 20%; 500V	C50089-1
C90	Ceramic, 220uf, 1000V	C50072-20
C91	Mylar, .047uf 250V	C50197-52
C92	Ceramic, .005uf 20%; 500V	C50089-1
C93	Ceramic, .02uf + 80 — 20%, 500V	C50089-4
C94, 95	Ceramic, 330uuf, 1000V	C50072-1
C96	Mylar, .015uf, 250V	C50197-58
C97	Ceramic, 820uuf, 5%; 500V	CC21GP821J5
C98	Ceramic, 330uuf, 1000V	C50072-1
C99	Ceramic, .0033uf; 1000V	C50072-11
C100	Electrolytic, 8uf, 50V	C629-138
C101	Mylar, .1uf, 250V	C50197-54
C102	Ceramic, .005uf, 20%; 500V	C50089-1
C110, 111	Ceramic, 220uuf, 1000V	C50072-20
C112, 113	Ceramic, 100uuf, GMV; 1000V	C50070-5
C114, 115	Mylar, .01uf, 250V	C50197-48
C116, 117	Mylar, .022uf, 250V	C50197-49
C118, 119	Ceramic, 24uuf, 5%, N150; 1000 V	C50070-8
C120, 121	Ceramic, 2700uuf; 1000V	C50072-17
C122	Ceramic, .0033uf; 1000V	C50072-11
C123	Electrolytic, 25uf; 6V	C639-114
C124	Ceramic, .0033uf; 1000V	C50072-11
C125	Electrolytic, 25uf, 6V	C639-114
C126, 127	Mylar, .047uf, 250V	C50197-52
C128, 129	Ceramic, .005uf, 20%; 500V	C50089-1
C130, 131	Mylar, .68uf; 250V	50197-57
C132, 133	Mylar, .027uf, 250V	50197-50
C134, 135	Ceramic, 330uuf; 1000V	C50072-11
C136	Ceramic, 56uuf, N1500; 1000V	C50070-22
C137	Ceramic, 47uuf, N750; 1000V	C50070-4
C138, 139	Mylar, .1uf; 250V	C50197-54
C140	Electrolytic, 25uf, 6V	C639-114
C141	Ceramic, .001uf; 1000V	C50072-3
C142	Electrolytic, 25uf; 6V	C639-114
C143	Ceramic, .001uf; 100V	C50072-3
C144, 145	Electrolytic, 25uf; 6V	C639-114
C146, 147	Mylar, .1uf; 250V	C50197-54
C148, 149	Ceramic, .02uf + 80 — 20%; 500V	C50089-4
C150, 151, 152, 153,		
154	Mylar, .1uf; 250V	C50197-54
C155, 156	Ceramic, .001uf, GMV, 500V	C50089-2

## RESISTORS AND POTENTIOMETERS

In ohms, 10% tolerance, 1/2 watt, unless otherwise noted. K = kilohm, M = megohm.

Symbol	Description	Part No.
R1	Composition 330	RC20BF331K
R2	Composition 2.7K	RC20BF272K
R3	Composition 330	RC20BF331K
R4	Composition 1K	RC20BF102K
R5	Composition 4.7	RC20BF477K
R6	Composition 100K	RC20BF104K
R7	Composition 4.7M	RC20BF475K
R8	Composition 120	RC20BF121K
R9	Composition 3.3M	RC20BF335K
R10	Composition 120	RC20BF121K
R11, 12	Composition 330K	RC20BF334K
R13	Composition 47K	RC20BF473K
R14	Composition 1K	RC20BF102K
R15	Composition 22	RC20BF220K
R16	Composition .2.2K	RC20BF222K
R17	Composition 4.7	RC20BF477K
R18	Composition 820K	RC20BF824K
R19	Composition 1K	RC20BF102K
R20	Composition 100	RC20BF101K
R21	Composition 470K	RC20BF474K
R22	Composition 22K	RC20BF223K
R23	Composition 1K	RC20BF102K
R24	Composition 2.2K, 1W	RC30BF222K
R25	Wirewound 100W	R592-185
R26	Composition 22K; 1W	RC30BF223K
R27	Composition 120	RC20BF121K
R28	Composition 1.2K; 1W	RC30BF122K
R29	Wirewound 400, 5%; 5W	R621-130
R30	Wirewound 12, 5W	R721-141
R31	Composition 1K	RC20BF102K

Symbol	Description	Part No.
R32	Composition 1.2K, 1W	RC30BF122K
R33	Wirewound 400, 5%; 5W	R621-130
R34	Composition 47K	RC20BF473K
R35	Composition 82K	RC20BF823K
R36	Composition 1.8M	RC20BF185K
R37, 38	Composition 1K	RC20BF102K
R39, 40	Composition 270	RC20BF271K
R41	Composition 1K	RC20BF102K
R42	Composition 10K	RC20BF103K
R43	Composition 68K	RC20BF683K
R44	Composition 470K	RC20BF474K
R45	Composition 120	RC20BF121K
R46	Composition 100	RC20BF101K
R47	Composition 10K	RC20BF103K
R48	Composition 100K	RC20BF104K
R49	Composition 1.8M	RC20BF185K
R50	Composition 15M	RC20BF156K
R51	Composition 3.3M	RC20BF335K
R52	Composition 68K	RC20BF683K
R53	Composition 56K	RC20BF563K
R54	Composition 470	RC20BF471K
R55	Composition 470K	RC20BF474K
R56	Potentiometer 250K; muting	R50160-3
R57	Composition 1K	RC20BF102K
R58	Composition 220K	RC20BF224K
R59	Composition 470K	RC20BF474K
R60	Composition 47K	RC20BF473K
R61	Composition 150K	RC20BF154K
R62	Composition 100K	RC20BF104K
R63, 64	Composition 270	RC20BF271K
R65	Composition 1.2M	RC20BF125K
R66	Composition 100K	RC20BF104K
R67	Composition 82K	RC20BF823K
R68	Composition 2.2M	RC20BF225K
R69	Composition 1K	RC20BF102K
R70	Composition 220K	RC20BF224K
R71	Composition 820K	RC20BF824K
R72	Potentiometer 250K, AM level set	R50160-3
R73	Composition 15K	RC20BF153K
R74	Composition 220K	RC20BF224K
R75	Composition 1K	RC20BF102K
R76	Composition 220K	RC20BF224K
R77	Composition 27K	RC20BF273K
R78	Composition 100	RC20BF101K
R79	Composition 18K	RC20BF183K
R80	Composition 47K	RC20BF473K
R81	Composition 1K	RC20BF102K
R82	Composition 47K	RC20BF473K
R83	Composition 22K, 1W	RC30BF223K
R84	Composition 1K	RC20BF102K
R85	Composition 3.3M	RC20BF335K
R86	Composition 270	RC20BF271K
R87	Composition 180	RC20BF181K
R88	Composition 470K	RC20BF474K
R89	Composition 100K, 5%	RC20BF104J
R90	Composition 68K	RC20BF683K
R91	Composition 1.5K	RC20BF152K
R92	Composition 1K	RC20BF102K
R93, 94	Composition 6.8K	RC20BF682K
R95	Composition 330K	RC20BF334K
R96	Composition 33K, 5%	RC20BF333J
R97	Potentiometer 100K, MPX, Control	R50160-20
R105	Potentiometer 250K, Tape rec. level ch. A	R50160-3
R106, 107	Composition 82K	RC20BF823K
R108	Potentiometer, 250K, Tape rec. level ch. B	R50160-3
R109	Composition 100K	RC20BF104K
R110	Composition 10K	RC20BF103K
R111	Composition 100K	RC20BF104K
R112	Composition 10	RC20BF100K
R113	Composition 10K	RC20BF103K
R114	Composition 10	RC20BF100K
R115	Composition 330K, 1W	RC30BF334K
R116	Composition 2.7K, 1W	RC30BF272K
R117	Composition 330K, 1W	RC30BF334K
R118	Composition 2.7, 1W	RC30BF272K
R119, 120	Composition 4.7M	RC20BF475K
R121, 122	Composition 220K	RC20BF224K
R123, 124	Potentiometer, 250K, Phono Level Sets	R50160-3
R125, 126	Composition 470K	RC20BF474K
R127	Composition 2.2M	RC20BF225K
R128	Composition 470K	RC20BF474K
R129	Composition 2.2M	RC20BF225K
R130	Composition 470K	RC20BF474K
R131, 132	Composition 470	RC20BF471K
R133	Composition 270K	RC20BF274K
R134, 135	Composition 330K	RC20BF334K
R136	Composition 270K	RC20BF274K

Symbol	Description	Part No.
R137, 138	Composition 47K	RC20BF473K
R139, 140	Composition 470K	RC20BF474K
R141	Composition 220	RC20BF221K
R142	Composition 10K	RC20BF103K
R143	Composition 220	RC20BF221K
R144, 145	Composition 10K	RC20BF103K
R146, 147	Composition 22K	RC20BF223K
R148	Composition 10K	RC20BF103K
R149	Potentiometer, dual, 100K, volume	R50160-29
R150	Potentiometer, dual, 1M, Bass	R50160-30
R151	Potentiometer, dual, 500K, treble	R50160-28
R152, 153	Composition 10M	RC20BF105K
R154, 155	Composition 470K	RC20BF474K
R156, 157	Composition 1.8K	RC20BF182K
R158, 159	Composition 100K	RC20BF104K
R160, 161	Composition 2.2M	RC20BF225K
R162	Composition 100K	RC20BF104K
R163	Composition 1.8K	RC20BF182K
R164	Composition 3.3M	RC20BF335K
R165	Composition 100K	RC20BF104K
R166	Composition 1.8K	RC20BF182K
R167	Composition 3.3M	RC20BF335K
R168	Potentiometer, triple, 500K, balance 250K, center ch. volume	R50160-31
R169, 170	Composition 1M	RC20BF105K
R171, 172	Composition 68K	RC20BF683K
R173	Composition 6.8K	RC20BF683K
R174	Composition 680	RC20BF681K
R175	Composition 6.8K	RC20BF682K
R176	Composition 1.5K	RC20BF152K
R177	Composition 47K	RC20BF473K
R178, 179, 180	Composition 470K	RC20BF474K
R181	Composition 1M	RC20BF105K

### COILS, CHOKES AND TRANSFORMERS

Symbol	Description	Part No.
L1	Choke, 3.3 micro henries	L50066-8
L2	Coil, FM Antenna	L726-124
L3	Coil, AM Antenna	L721-139
L4	AM Ferrite Antenna	L721-136
L5	Choke, 1 micro henry	L50066-2
L6, 7	Choke, .56 micro henries	L50066-19
L8	Choke, R.F.	L629-180
L9	Coil, FM, R.F.	L726.126
L10	Coil, FM, osc.	L726-125
L11	Choke, .56 micro henries	L50066-19
L12, 13	Choke, 1 micro henry	L50066-2
L14	Choke, 1.2 micro henries	L50066-3
L15	Coil, AM, osc.	L50210-22
L16	Coil, muting, osc.	L50210-21
L17	Coil, 10KC, filter	L644-120
L18	Choke, 1.2 micro henries	L50066-3
L19, 20, 21, 22, 23	Choke, filament ferrite bead	L592-189
T1	Transformer, power	T721-115
Z1	Transformer, FM, I.F.	ZZ662-117
Z2	Transformer, FM, I.F.	ZZ629-142
Z3	Transformer, FM, I.F.	ZZ50210-2
Z4	Coil, FM, limiter	L551-121
Z5	Transformer, FM, Ratio Detector	ZZ592-170
Z6	Transformer, AM, R.F.	L670-151
Z7, 8	Transformer, AM, I.F.	ZZ50210-3
Z9	Transformer, AM, I.F.	ZZ2984

### MISCELLANEOUS

Symbol	Description	Part No.
CR1, 2	Crystal diode, Type 1N295	V-1N295
CR3, 4	Crystal diode, Type 1N542, matched pair	V-1N542
F1	Fuse, 3 amp.	F-3000
I1, 2	Lamp, dial panel	I-50082-3
PI, 2	Plug, 9-pin	P-50181
PC1, 2	Printed circuit, Phone Equalization	PC50187-3
PC3, 5	Printed circuit, Tone Control	PC657-140
PC4, 6	Printed circuit, High Freq. filter	PC50187-2
S1	Switch, selector	S721-116
S2	Switch, mono stereo	S721-117
S3, 5, 6, 7, 8, 9, 11, 12	Switch slide	S50200-2 or S50200-4
S4	Switch, power	Part of R149
S10	Switch, loudness	Part of R149
SR1	Selenium rectifier	SR721-143

# ALIGNMENT INSTRUCTIONS

## Read These Instructions With Extreme Care Before Attempting Alignment.

**CHASSIS:** Turn the station selectors completely counterclockwise, without forcing. Dial pointers should be at zero index mark on logging scale. If not, reset the dial pointers. Disconnect the external antennas and the antenna link. Set Ferrite Loop to normal position, parallel to rear panel. When using an oscilloscope for alignment, set the output level controls for no overload, as shown by the proper waveform shape.

**SIGNAL GENERATORS:** The signal generator equipment must be able to supply the following: FM RF modulated 30% ( $\pm 22.5$  KC deviation) at 400 cps; AM RF modulated 30% at 400 cps;

AM IF with 30 KC sweep for AM bandwidth adjustment; audio oscillator accurately calibrated for 1 and 10 KC audio output for testing the 10 KC AM whistle filter.

**INDICATOR:** DC VTVM, AC VTVM, and scope for alignment.

**ALIGNMENT:** Allow the chassis and test instruments to warm up for at least fifteen minutes. Adjust the line voltage for 117 volts AC, 50-60 cycles. Use fully insulated tools: a small screwdriver for all trimming capacitors; a K-Tran tool for Z1, Z2, Z3, Z6, Z7, Z8 and Z9; a hex tool for Z4, Z5, L2, L9, L10, L15 and L16. For AM alignment, connect a 1.4 volt battery between the junction of R68/C54 and ground. Positive side of battery to ground.

## AM ALIGNMENT

STEPS	CHASSIS				SIGNAL GENERATOR			INDICATOR		ALIGNMENT	
	AM BANDWIDTH	SELECTOR	MONO-STEREO	STATION SELECTOR	COUPLING	FREQ.	MOD.	TYPE	CONNECTION	ADJUST	INDICATION
1	SHARP	FM-AM	B (AM)	Point of no signal and no interference	Audio Gen. connected to Pin 7 of V12	10 KC	None	AC VTVM to Ch. B Recorder Output		C85	Minimum Output
2	SHARP	FM-AM	B (AM)	Point of no signal and no interference	AM RF Gen. connected thru .01-uf cap. in series with hot lead to V10 Pin 1	455 KC	30% AM at 400 cps	DC VTVM to Test Point 7		Z7, Z8, Z9 top and bottom	Maximum negative voltage
3	BROAD	FM-AM	B (AM)	Point of no signal and no interference	AM Gen. connected thru .01-uf cap. in series with hot lead to V10 Pin 1	455 KC	30 KC sweep	Scope to Ch. B Recorder Output		Z9 top	Adjust slightly for symmetrical curve
4	SHARP	FM-AM	B (AM)	600 KC	AM Gen. connected thru 220-uuf cap. in series with hot lead to antenna terminal 3	600 KC	30% AM at 400 cps	Scope to Ch. B Recorder output. DC VTVM to Test Point 7		L15, Z6	Check for sine waveform Maximum negative voltage
5	SHARP	FM-AM	B (AM)	1400 KC	AM Gen. connected thru 220-uuf cap. in series with hot lead to antenna terminal 3	1400 KC	30% AM at 400 cps	Scope to Ch. B Recorder output. DC VTVM to Test Point 7		C6E, C6C C6A	Check for sine waveform Maximum negative voltage
6	Repeat steps 4 and 5 for proper dial calibration and maximum output.										
7	FM Muting Switch Off	FM-AM	A (FM)	Point of no signal and no interference	FM Generator connected to Pin 1 of V4	10.7 MC	None	Connect VT VM to test point 2		Z4, Z5 top Z5 bottom	Maximum negative voltage (below -5 volts) See Note 2
8	FM Muting Switch Off	FM-AM	A (FM)	Point of no signal and no interference	FM Generator connected to Pin 1 of V4	10.7 MC	None	DC VTVM to test point 4		Z5 top	Zero reading on zero center scale
9	FM Muting Switch Off	FM-AM	A (FM)	Point of no signal and no interference	FM Gen. connected to ungrounded tube shield of V2	10.7 MC	None	DC VTVM to test point 1		Z1, Z2, Z3 top & bottom	Maximum negative voltage (below -2 volts) See Note 2
10	FM Muting Switch Off	FM-AM	A (FM)	90 MC	FM Gen. connected thru two 120-ohm carbon resistors in series with lead to antenna terminals 5 and 6	90 MC	30% FM (22.5 KC Dev.) at 400 cps	DC VTVM to test point 1, and scope to Ch. A Recorder Output		L10, L9 L2	Check for sine waveform and adjust for maximum negative voltage
11	FM Muting Switch Off	FM-AM	A (FM)	106 MC	FM Gen. connected thru two 120-ohm carbon resistors in series with lead to antenna terminals 5 and 6	106 MC	30% FM (22.5 KC Dev.) at 400 cps	DC VTVM to test point 1, and scope to Ch. A Recorder Output		C31, C21 C5	Check for sine waveform and adjust for maximum negative voltage
12	Repeat steps 10 and 11 at least once for proper dial calibration and maximum output.										
<p><b>NOTE:</b> 1 — For calibrating both the AM and FM, use as low an output voltage as possible from your signal generator.                  2 — Decrease Signal Generator output while adjusting IF transformers so that DC VTVM shows no more than noted voltage.                  3 — If adjustment of muting oscillator is necessary, adjust it for 3 MC with a Grid-dip Meter.</p>											

## FM ALIGNMENT

# SCHEMATIC DIAGRAM • FM-AM TUNING SECTIONS

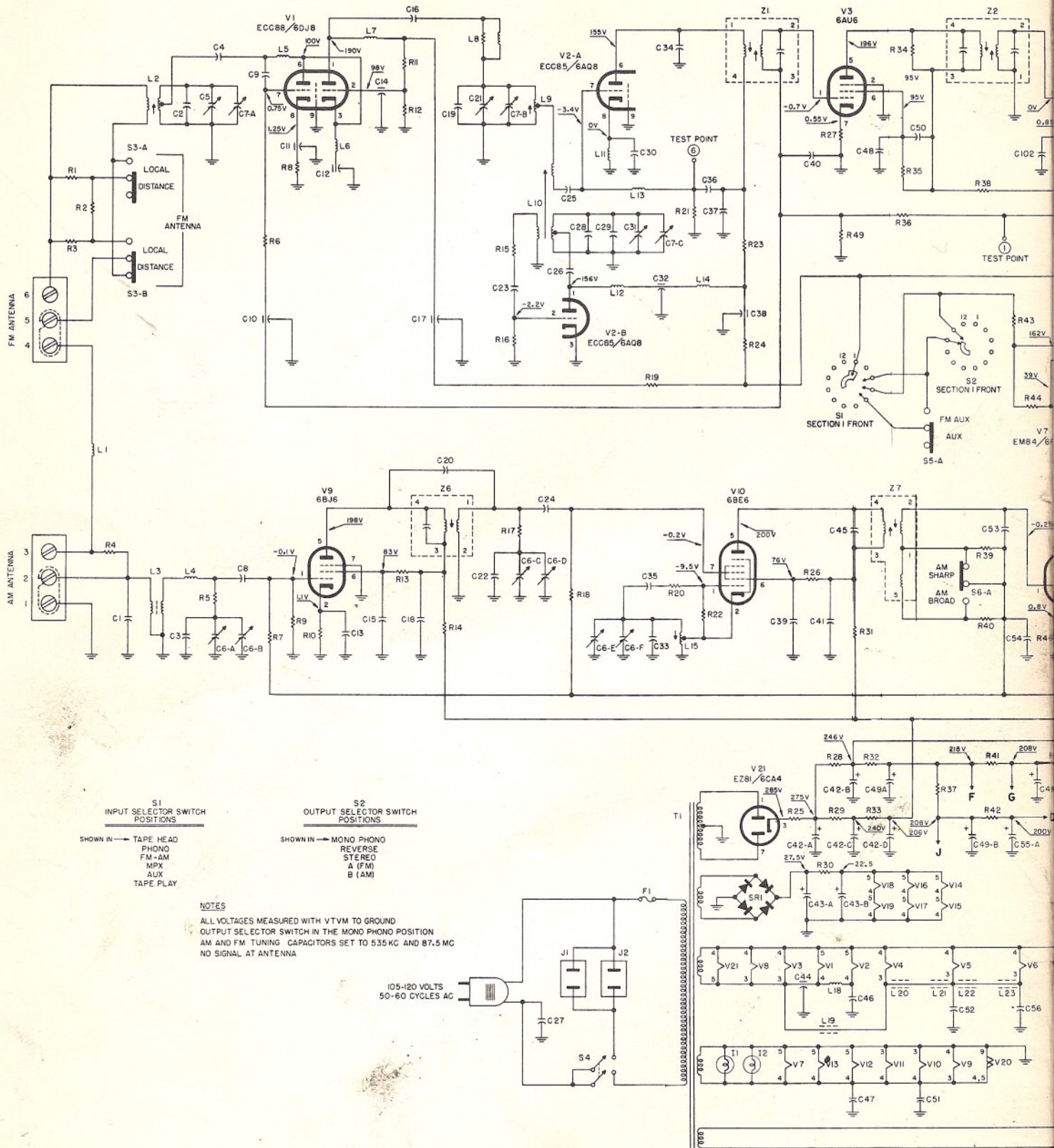

RESISTORS	R1 R2 R3	R4	R5	R6 R7	R8 R9 R10	R11 R12 R13	R14	R15 R16 R17	R18	R19 R20	R21	R22	R23 R24	R25 R26 R27 R28 R29 R30	R31 R32 R33	R34 R35 R36	R37	R38 TO R42	R43 R44	R45 R46 R47 R48 R49 R50 R51 R52 R53 R54 R55 R56 R57 R58 R59 R60 R61 R62 R63 R64 R65 R66 R67 R68 R69 R70 R71 R72 R73 R74 R75 R76 R77 R78 R79 R80 R81 R82 R83 R84 R85 R86 R87 R88 R89 R90 R91 R92 R93 R94 R95 R96 R97 R98 R99 R100
CAPACITORS	C1	C2 C3	C4 C5 C6-A C8	C6-B C9 C7-A C10 C8	C11 C12 C13	C14 C15 C16 C17 C18	C19 C20	C21 C22	C6-C C24 C26 C27	C6-D C25 C28 C29	C6-E C30 C33	C6-F C29	C30 C34 C35 C36 C37	C38	C39 C40 C44	C45 C46 C47 C48 C49 C50	C48 C51 C52	C53 C54 C55 C56	C53 C54 C55 C56	



# SCHEMATIC DIAGRAM • PREAMPLIFIER

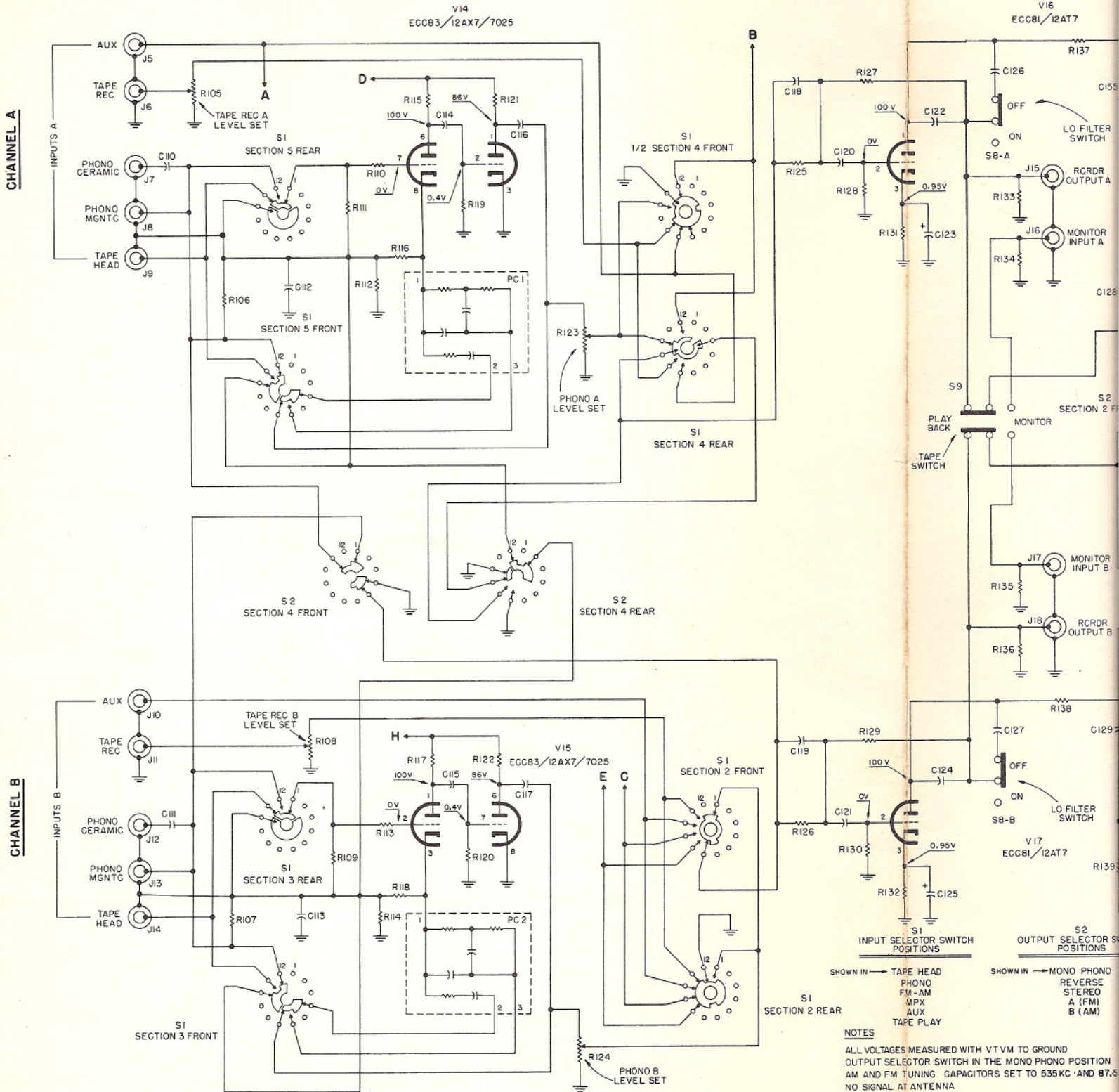

RESISTORS	R105	R106 R107	R108	R109	R110 TO R114	R115 TO R118	R119 R120	R121 R122	R123 R124	R125 R126	R127 TO R130	R131 R132	R133 TO R136	R137 R138	R139
CAPACITORS	C110 C111		C112 C113			C114 C115	C116 C117			C118 C119	C120 C121	C122 TO C125	C126 C127		C128 C129

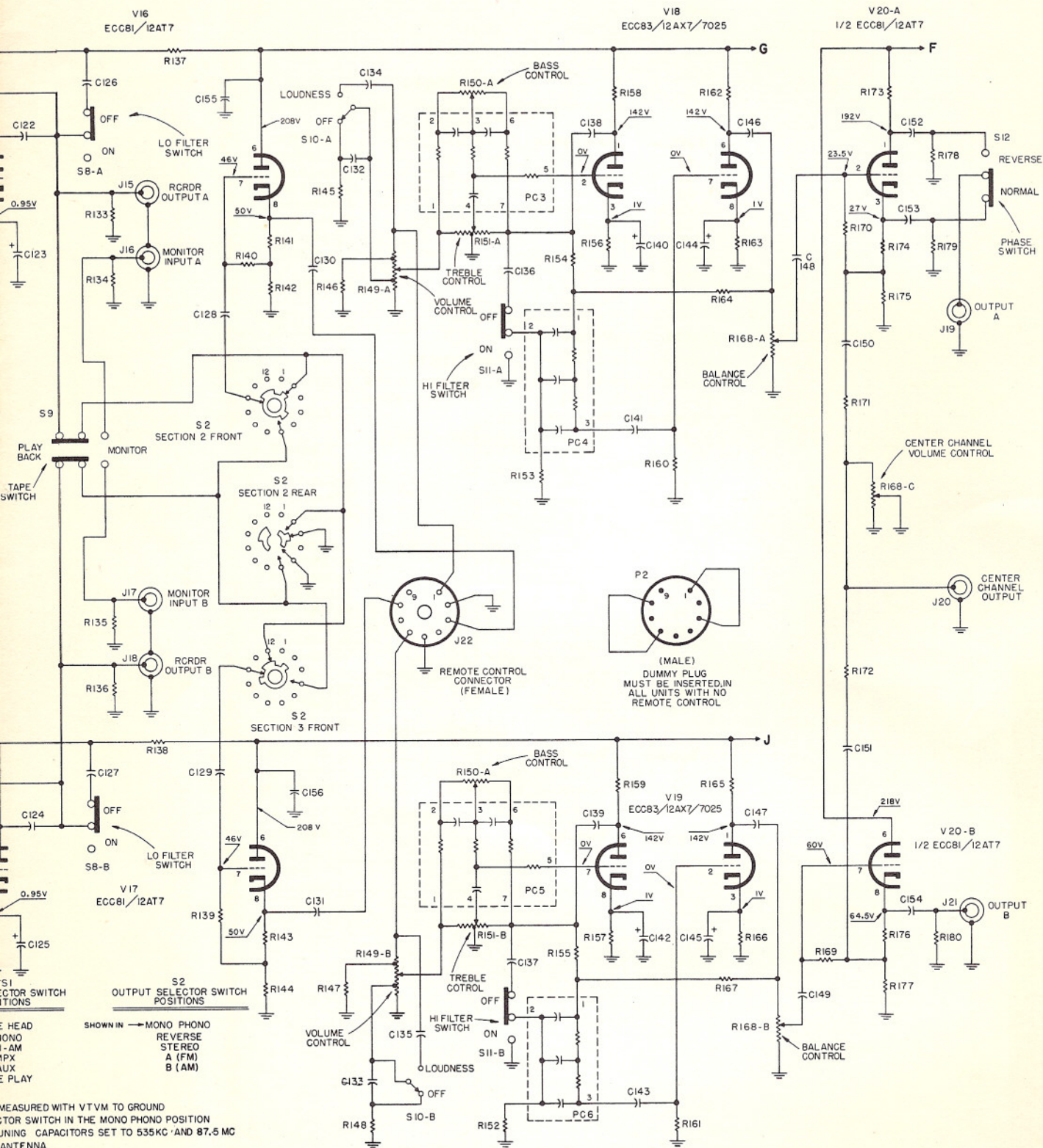

P721 SCHEMATIC AW#1667  
 SHEET 2 OF 2

R133 TO R136	R137 R138	R139	R140	R141 TO R144	R145 R146 R147	R148 R149	R150 R151	R152	R153	R154 R155	R156 TO R159	R160 R161	R162 TO R167	R168	R169	R170 R171 R172	R173 TO R177	R178 R179 R180	
C122 TO C125	C126 C127	C128 C129	C130	C131	C132 C133 C134	C135	C136	C137	C138	C139	C140 TO C143	C144	C146 C147	C148 C149	C150	C151	C152	C153 C154	



# SCHEMATIC DIAGRAM • AMPLIFIER 100

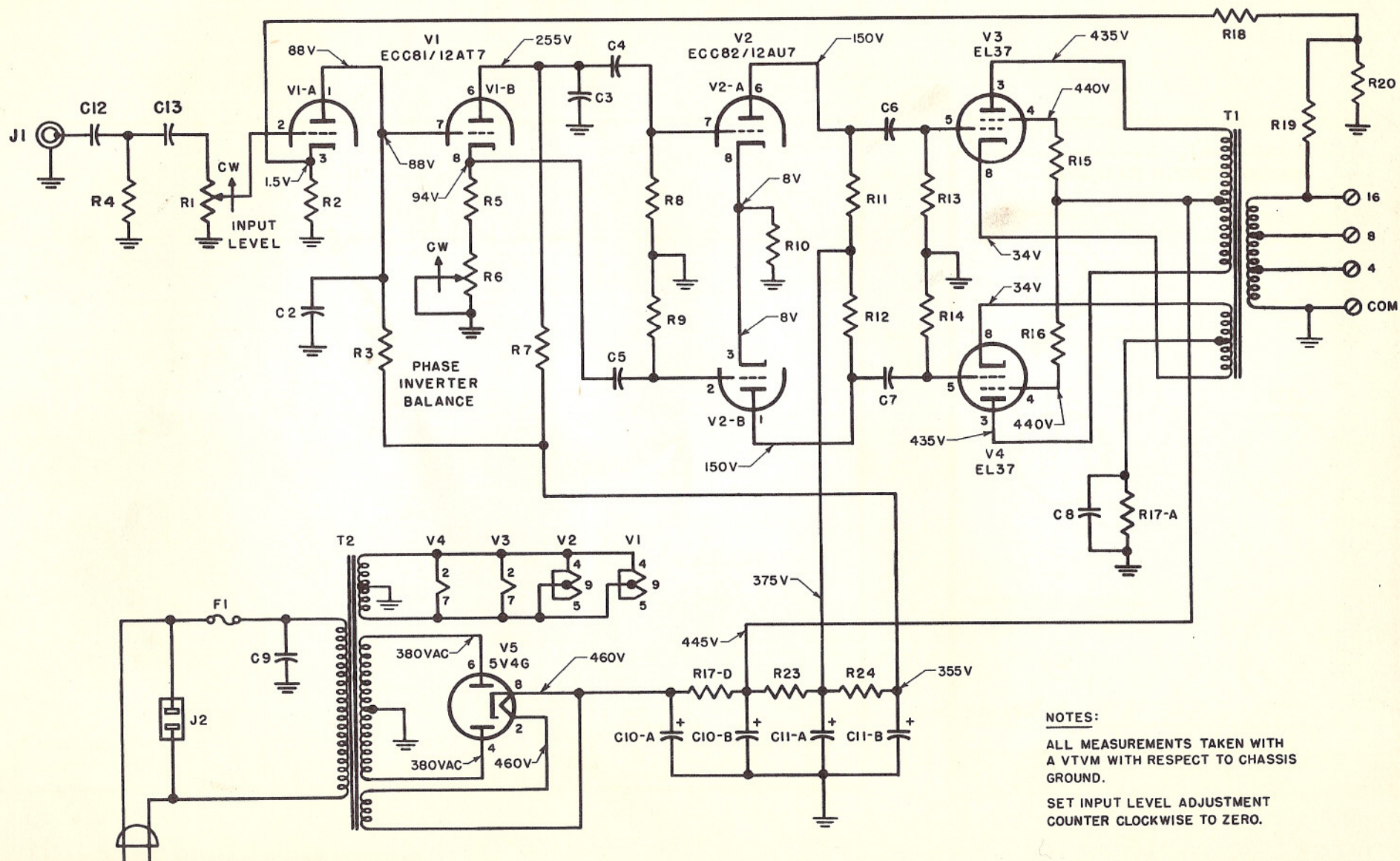

**NOTES:**  
 ALL MEASUREMENTS TAKEN WITH  
 A VTVM WITH RESPECT TO CHASSIS  
 GROUND.  
 SET INPUT LEVEL ADJUSTMENT  
 COUNTER CLOCKWISE TO ZERO.

125-125 VOLTS AC  
 50-60 CYCLES

AW 1416 SCHEMATIC P649

# TUBE LAYOUT

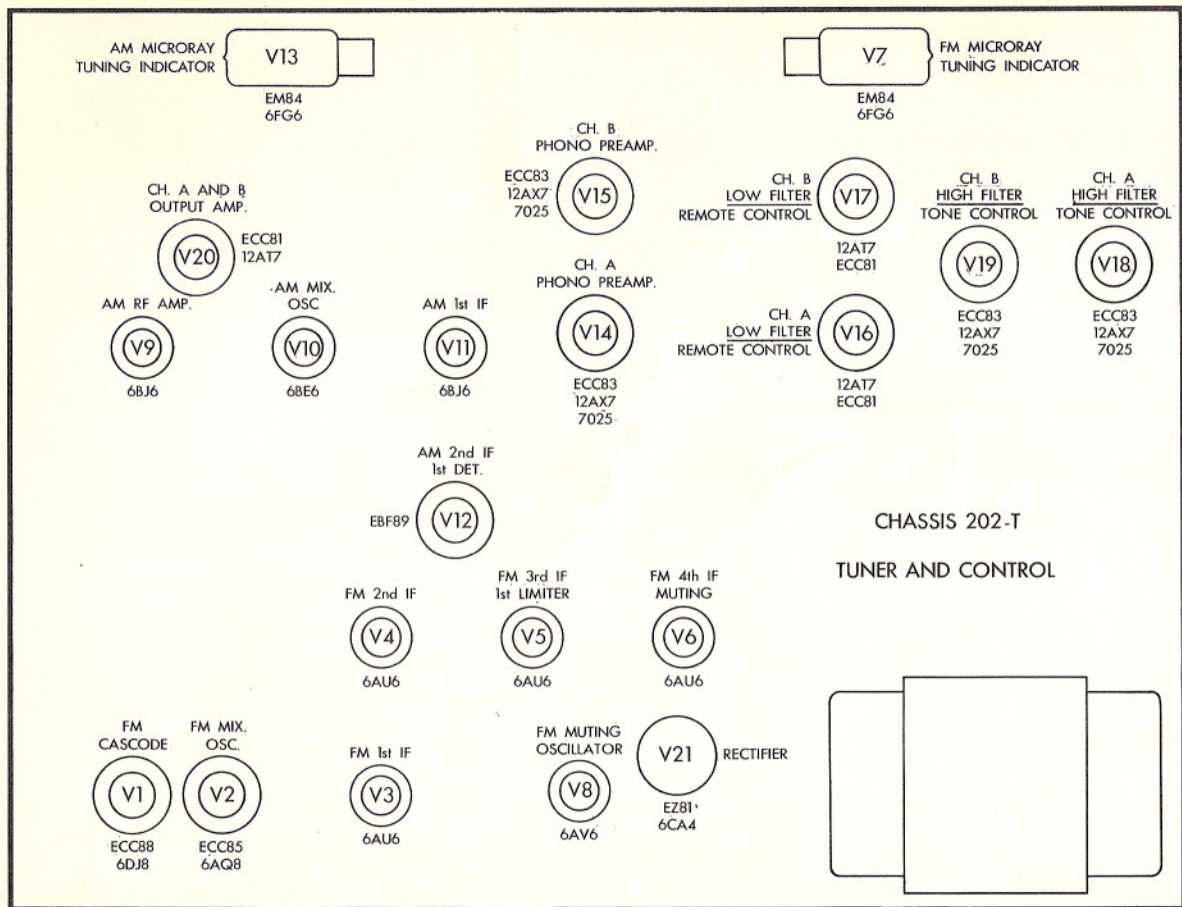

AW 1669

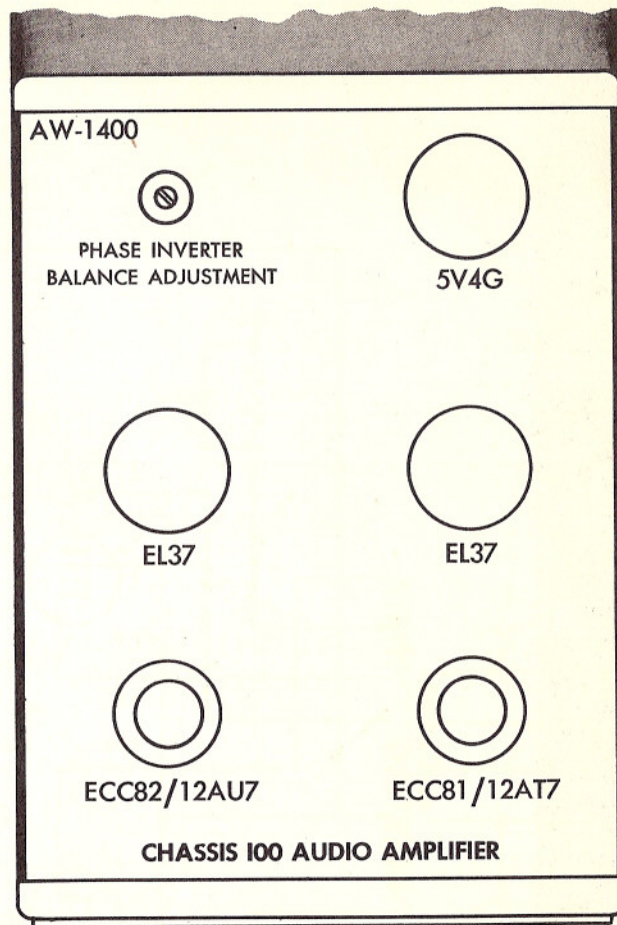

# PARTS DESCRIPTION LIST • AMPLIFIER 100

## CAPACITORS

20 % tolerance for all capacitors, unless otherwise noted.

Symbol	Description	Part No.
C1	Mylar .022uf, 10%, 250V	C50197-49
C2	Ceramic, 300uf, 10%, 500V	CC21GP301K5
C3	Ceramic, 120uf, 10%, 500V	CC21GP121K5
C4, 5	Molded tubular, .022uf, 400V	C68P223M4
C6, 7	Molded tubular, .047uf, 400V	C68P473M4
C8	Electrolytic, 50uf, 50V	C-508-115
C9	Molded tubular, .01uf, 600V	C-2747
C10	Electrolytic, two-section, each 40uf, 500V	C-522-114
C11	Electrolytic, two-section, each 40uf, 450V	C-1798
C12	Mylar, .01uf, 10%, 250V	C50197-48

## RESISTORS

Values in ohms, 10 % tolerance, 1/2 watt, unless otherwise noted. K=Kilohms. M=Megohms.

Symbol	Description	Part No.
R1	Potentiometer, composition, 500K, 1/4 W, input level	R-2815-9
R2	Composition, 1500	RC20BF152K
R3	Composition, 220K	RC20BF224K
R4	Composition, 470K	RC20BF474K
R5	Composition, 82K	RC20BF823K
R6	Potentiometer, composition, 50K, 1/4 W, phase inverter balance	R-50000-5
R7	Composition, 100K	RC20BF104K
R8, 9	Composition, 470K	RC20BF474K
R10	Composition, 2700	RC20BF272K
R11, 12	Composition, 150K	RC20BF154K
R13, 14	Composition, 470K	RC20BF474K
R15, 16	Composition, 68	RC20BF680K
R18	Composition, 4700	RC20BF472K
R19	Composition, 2200	RC20BF222K
R20	Composition, 330	RC20BF331K
R23, 24	Composition, 10K, 1W	RC30BF103K

## TRANSFORMERS

Symbol	Description	Part No.
T1	Transformer, output	T-557-145
T2	Transformer, power	T-649-114

## MISCELLANEOUS

Symbol	Description	Part No.
F1	Fuse, 3 ampere	F-3000
J1	Jack, input	J-3143
J2	Receptacle, auxiliary AC	J-546-129

# SCHEMATIC DIAGRAM · SPEAKER SYSTEMS

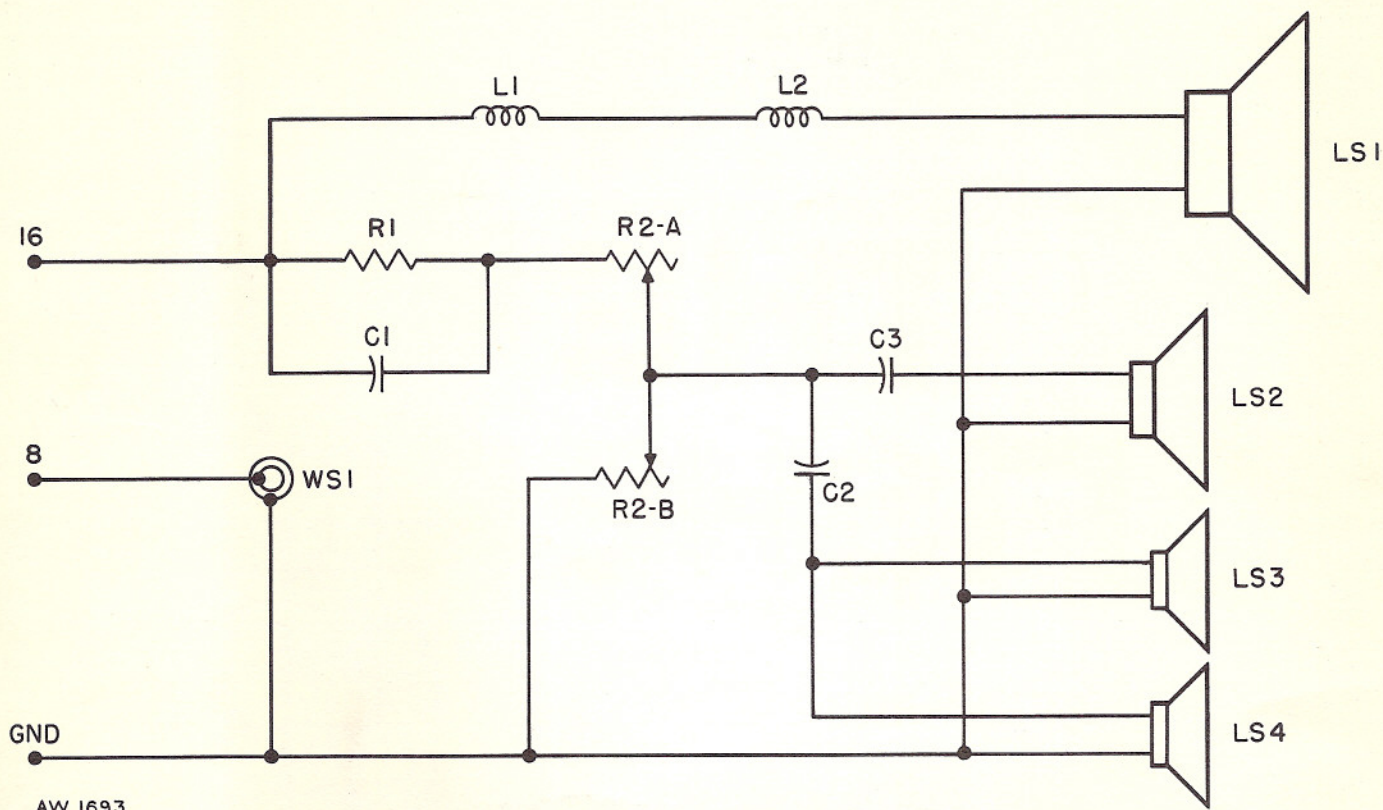

AW 1693

# PARTS DESCRIPTION LIST · SPEAKER SYSTEMS

Symbol	Description	Part No.
C1	Electrolytic, Non-Polarized, 5uf, 20%, 50V	C769-105
C2	Paper, Non-Polarized, 2uf, 20%, 50V	C547-118
C3	Paper, Non-Polarized, 8uf, 20%, 50V	C687-120
L1, 2	Coil, 3MH	L547-120
LS1	Speaker, 12 Inch, Woofer	LS777-104
LS2	Speaker, 8 Inch, Mid-Range	LS547-123
LS3	4 Speaker, Tweeter	LS769-104
R1	Wire Wound, 50 Ohms, 10%, 5W	R556-142
R2	L-Pad, Wire Wound, 15 Ohms	M211



**FISHER RADIO CORPORATION · NEW YORK**

